



QUBE SQUHT

Centrifugal Box Fan

QUBE SQUHT

Product Overview

- 6 physical sizes from 315mm to 710mm
- Air volume flow rates of up to 3.9 m³/s
- Static pressures up to 1120 Pa
- Suitable for operating temperatures up to +120°C (in-duct)
- Inverter speed controllable via 1Ph and 3Ph supply
- Interchangeable double skinned panels
- Available in **AC**

A multi-discharge, double skinned fan unit incorporating a high performance backward curved impeller. The motor is situated out of the airstream making the range suitable for more arduous and elevated temperature applications. Units are supplied as either an end inlet discharge unit (Qube SQUHT) or as a side inlet discharge unit (Qube SQUHTS)*.

High Temperature

Motors are out of the air stream and are not effected by contaminants in the ventilated air. The range is suitable for a wide range of applications from contaminated air to elevated temperatures up to 120°C.

Intelligent Design

Movable panels allow the inlet and outlet position to be altered on site to suit installation. DW172 models for kitchens meet system velocity requirements.

Low Noise

Units are constructed from double insulated panels filled with 25mm fibre glass acoustic insulation giving reduced noise levels.

Easy Maintenance

An easily removable motor/impeller assembly arrangement is ideal for frequent cleaning or maintenance.

Controllability

The Eltadrive range of inverters has been designed encompassing the latest technology and combining robustness with reliability. Using an inverter to control

fans via sensors to reduce fan speed can provide significant cost-savings through lower energy consumption.

Warranty

Each SQUHT has a 12 month warranty.

Construction

Constructed from self supporting corrosion-resistant extruded Aluminium section. Assembled with aluminium corners and 25mm thick double skinned removable panels, manufactured from pre-galvanised steel and in-filled with a non flammable mineral wool, 60kg/m³.

Motor

Three phase multi-voltage IP55 TEFC foot/flange mounted IEC frame motors, wound for either (Delta) 230V/3Ph/50Hz or (Star) at 400V/3Ph/50Hz connection, suitable for speed control when used with the Eltadrive VSD range of frequency inverter controls.

Impeller

A free running impeller with 7 backwards-curved blades made of sheet steel with surface protection provided by powder coating. The rotating, non-fluted diffuser generates high efficiency levels and favourable acoustic characteristics.

Typical Applications

- Kitchens
- Restaurants
- Schools
- Colleges
- Shops
- Shower Rooms
- Factories



Contents

Page	Information
3	Performance Range Curves
4	Performance, SFP & Electrical Data
5	Sound Data
6	Dimensional Data
7	Accessories

* Add 'S' to product code for side entry.

QUBE SQUHT



Performance Range Curves

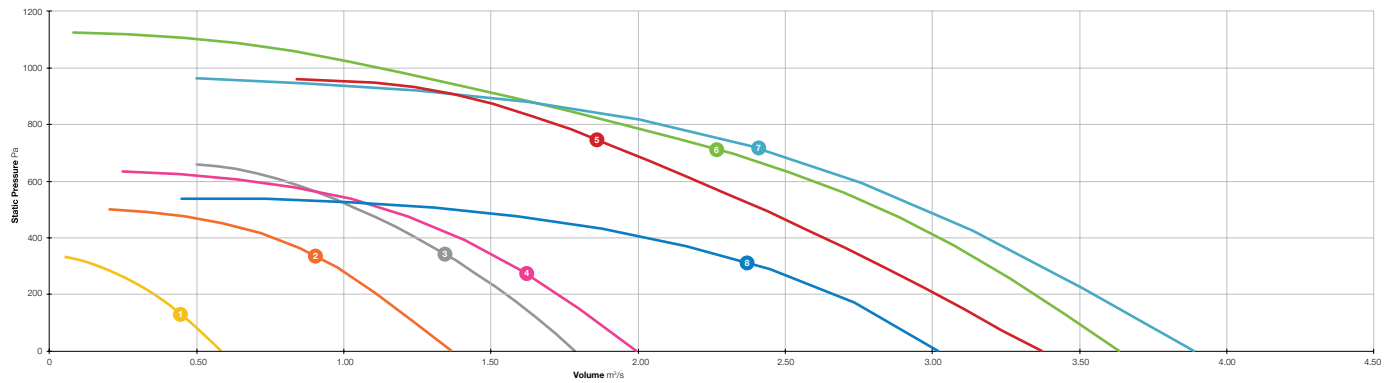

- 1 SQU1 / 4-3HT
- 2 SQU2 / 4-3HT
- 3 SQU22 / 4-3HT
- 4 SQU3 / 4-3HT
- 5 SQU23 / 4-3HT
- 6 SQU24 / 4-3HT
- 7 SQU4 / 4-3HT
- 8 SQU4 / 6-3HT

QUBE SQUHT



Performance, SFP & Electrical Data

Three Phase 380V to 415V / 50Hz

Product Code	Speed r/min	Airflow SFP	Airflow m³/s @ Static Pressure Pa								At Best Efficiency Point		Electrical Data			dBA @ 3m		
			0	100	200	300	400	500	600	800	1000	Overall Eff %	Input kW	Peak Amps	FLC* Amps			FLC# Amps
SQU1/4-3HT	1441	m³/s	0.582	0.478	0.354	0.162	-	-	-	-	-	33.4	0.252	0.81	2.30	1.02	Inlet	51
		W/(L/s)	0.32	0.46	0.76	1.32	-	-	-	-	-						Outlet	53
		Breakout	38															
SQU2/4-3HT	1445	m³/s	1.367	1.241	1.115	0.968	0.764	-	-	-	-	54.2	0.542	1.42	5.30	2.05	Inlet	57
		W/(L/s)	0.31	0.45	0.63	0.87	1.14	-	-	-	-						Outlet	59
		Breakout	44															
SQU22/4-3HT	1470	m³/s	1.785	1.676	1.552	1.409	1.245	1.051	0.800	-	-	53.8	1.054	2.23	8.50	3.17	Inlet	60
		W/(L/s)	0.50	0.58	0.67	0.76	0.88	1.01	1.21	-	-						Outlet	62
		Breakout	47															
SQU3/4-3HT	1471	m³/s	1.993	1.866	1.729	1.576	1.393	1.147	0.691	-	-	60.1	1.077	2.40	8.50	3.17	Inlet	66
		W/(L/s)	0.38	0.48	0.59	0.74	0.91	1.11	1.44	-	-						Outlet	68
		Breakout	47															
SQU23/4-3HT	1445	m³/s	3.370	3.187	3.013	2.831	2.634	2.423	2.201	1.725	-	54.1	2.734	5.48	-	6.20	Inlet	66
		W/(L/s)	0.87	0.91	0.97	1.03	1.11	1.20	1.30	1.57	-						Outlet	68
		Breakout	53															
SQU24/4-3HT	1435	m³/s	3.635	3.493	3.348	3.195	3.027	2.833	2.600	1.951	1.126	58.6	2.894	5.50	7.60	2.80	Inlet	66
		W/(L/s)	0.54	0.63	0.72	0.81	0.90	1.00	1.11	1.44	2.05						Outlet	68
		Breakout	48															
SQU4/4-3HT	1447	m³/s	3.889	3.720	3.550	3.373	3.185	2.980	2.745	2.086	-	64.8	2.898	6.50	-	6.20	Inlet	66
		W/(L/s)	0.49	0.59	0.71	0.83	0.99	1.17	1.37	1.79	-						Outlet	68
		Breakout	48															
SQU4/6-3HT	910	m³/s	3.019	2.866	2.673	2.415	2.037	1.372	-	-	-	66.9	1.352	3.90	7.60	2.80	Inlet	59
		W/(L/s)	0.39	0.46	0.55	0.69	0.86	1.04	-	-	-						Outlet	61
		Breakout	46															

The unit is supplied as either an end inlet vertical discharge unit (SQU-HT) or as a side inlet vertical discharge unit (SQU-HTS).

* FLC Amps at 230V / 1Ph / 50Hz input before a 1Ph to 3Ph Variable Speed Drive.

FLC Amps at 400V / 3Ph / 50Hz input before a 3Ph to 3Ph Variable Speed Drive.

Exempt from ErP of the European Parliament.

A variable speed drive (Eltadrive) must be installed with this fan.

Data provided is at standard air density of 1.2 kg/m³.

Peak Amps @ 400V / 3PH / 50Hz.

The overall A-weighted sound pressure level is at a distance of 3m with spherical free-field propagation. It is expressed in dB re-20µPa and is presented for comparative purposes only.

Sound Data

Three Phase 380V to 415V / 50Hz

Product Code	Speed r/min		Sound Power Level dBW @ Octave Band Hz							Total dB	
			63Hz	125Hz	250Hz	500Hz	1kHz	2kHz	4kHz		8kHz
SQU1/4-3HT	1441	Inlet	62	66	70	70	66	62	57	53	75
		Outlet	64	68	72	72	68	64	59	55	77
		Breakout	63	65	63	57	52	44	37	28	69
SQU2/4-3HT	1445	Inlet	68	72	76	76	72	68	63	59	81
		Outlet	70	74	78	78	74	70	65	61	83
		Breakout	69	71	69	63	54	44	36	33	75
SQU22/4-3HT	1470	Inlet	72	76	80	79	76	71	67	62	85
		Outlet	74	78	82	81	78	73	69	64	87
		Breakout	73	75	73	66	59	52	43	38	79
SQU3/4-3HT	1471	Inlet	72	76	79	79	75	71	67	62	84
		Outlet	74	78	81	81	77	73	69	64	86
		Breakout	73	75	72	66	58	52	43	38	79
SQU23/4-3HT	1445	Inlet	78	82	86	85	81	77	73	68	91
		Outlet	80	84	88	87	83	79	75	70	93
		Breakout	79	81	79	72	62	53	42	36	85
SQU24/4-3HT	1435	Inlet	78	82	86	85	81	77	73	68	91
		Outlet	80	84	88	87	83	79	75	70	93
		Breakout	79	81	79	72	62	53	42	36	85
SQU4/4-3HT	1447	Inlet	78	82	86	85	81	77	73	68	91
		Outlet	80	84	88	87	83	79	75	70	93
		Breakout	77	76	73	68	59	52	41	33	81
SQU4/6-3HT	910	Inlet	73	76	79	78	74	70	65	61	84
		Outlet	75	78	81	80	76	72	67	63	86
		Breakout	74	75	72	65	56	49	42	31	79

Data provided at standard air density of 1.2 kg/m³.

Tests and preparation of the sound data have been carried out in accordance with BS 848 Part 2:1985 at 50% peak pressure.

The Sound Power Level Spectra are in dB re-1pW.

QUBE SQUHT



Dimensional Data

Three Phase

Product Code*	A	B	C	D	SPIGOT Ø	Side Inlet	Outlet	Weight kg
SQU1/4-3HT	500	197	280	63	315	203 x 440	219 x 440	43
SQU2/4-3HT	670	213	350	80	500	320 x 610	273 x 610	70
SQU22/4-3HT	670	257	350	80	400	320 x 610	273 x 610	89
SQU3/4-3HT	820	257	350	80	560	420 x 740	303 x 740	114
SQU23/4-3HT	820	293	474	80	500	420 x 740	303 x 740	144
SQU24/4-3HT	1020	293	474	99	630	571 x 940	352 x 940	173
SQU4/4-3HT	1020	293	474	99	710	571 x 940	352 x 940	172
SQU4/6-3HT	1020	293	474	99	710	571 x 940	352 x 940	190

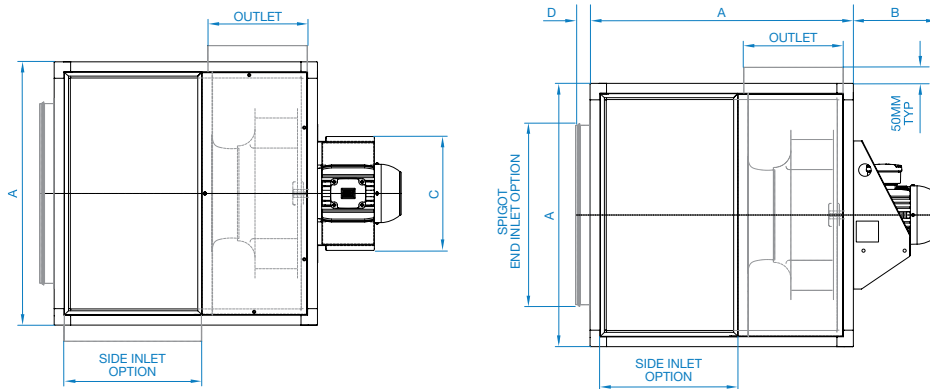

* Add 'S' to product code for side entry.
Dimensions are in mm.

Accessories

Three Phase

Product Code*	Eltadrive Variable Speed Drive 1PH-3PH IP66	Eltadrive Variable Speed Drive 1PH-3PH IP20	Eltadrive Variable Speed Drive 3PH-3PH IP66	Eltadrive Variable Speed Drive 3PH-3PH IP20	Flanged Silencer 1D Unpodded	Flanged Silencer 2D Unpodded
SQU1/4-3HT	149-ODE3-12037-1KB1Y	149-ODE3-12037-1KB12	149-ODE3-14075-3KA1Y	149-ODE3-14075-3KA12	068-0315-1DENP	068-0315-2DENP
SQU2/4-3HT	149-ODE3-12075-1KB1Y	149-ODE3-12075-1KB12	149-ODE3-14075-3KA1Y	149-ODE3-14075-3KA12	068-0500-1DENP	068-0500-2DENP
SQU22/4-3HT	149-ODE3-12151-1KB1Y	149-ODE3-12150-1KB12	149-ODE3-14150-3KA1Y	149-ODE3-14150-3KA12	068-0400-1DENP	068-0400-2DENP
SQU3/4-3HT	149-ODE3-12151-1KB1Y	149-ODE3-12150-1KB12	149-ODE3-14150-3KA1Y	149-ODE3-14150-3KA12	068-0560-1DENP	068-0560-2DENP
SQU23/4-3HT	-	-	149-ODE3-24400-3KA4Y	149-ODE3-24400-3KA42	068-0500-1DENP	068-0500-2DENP
SQU24/4-3HT	-	-	149-ODE3-24400-3KA4Y	149-ODE3-24400-3KA42	068-0630-1DENP	068-0630-2DENP
SQU4/4-3HT	-	-	149-ODE3-24400-3KA4Y	149-ODE3-24400-3KA42	068-0710-1DENP	068-0710-2DENP
SQU4/6-3HT	149-ODE3-22220-1KB4Y	149-ODE3-22220-1KB42	149-ODE3-24220-3KA4Y	149-ODE3-24220-3KA42	068-0710-1DENP	068-0710-2DENP

Product Code	High Temperature Flexible Connectors (each)	Matching Flanges (each)	TPI Transition Piece † (Inlet)	TPO Transition Piece (Outlet)	Vertical Weather Hood ‡	Wiring Diagram
SQU1/4-3HT*	063-0315-PU250	061B-0315	260-SQU-TPI-A	260-SQU-TPO-A	064-SQU-WHV-A	152-600
SQU2/4-3HT*	063-0500-PU250	061B-0500	260-SQU-TPI-B	260-SQU-TPO-B	064-SQU-WHV-B	152-600
SQU22/4-3HT*	063-0400-PU250	061B-0400	260-SQU-TPI-C	260-SQU-TPO-C	064-SQU-WHV-B	152-600
SQU3/4-3HT*	063-0560-PU250	061B-0560	260-SQU-TPI-D	260-SQU-TPO-D	064-SQU-WHV-C	152-600
SQU23/4-3HT*	063-0500-PU250	061B-0500	260-SQU-TPI-E	260-SQU-TPO-E	064-SQU-WHV-C	152-600
SQU24/4-3HT*	063-0630-PU250	061B-0630	260-SQU-TPI-F	260-SQU-TPO-F	064-SQU-WHV-D	152-600
SQU4/4-3HT*	063-0710-PU250	061B-0710	260-SQU-TPI-G	260-SQU-TPO-G	064-SQU-WHV-D	152-600
SQU4/6-3HT*	063-0710-PU250	061B-0710	260-SQU-TPI-G	260-SQU-TPO-G	064-SQU-WHV-D	152-600



Fan & inverter packages available.

Please contact Elta Fans for more information.

* Add 'S' to product code for side entry.

† HTS model only.

‡ For horizontal discharge only.

ELTADRIVE VARIABLE SPEED DRIVES

IP20

- Up to 22kW
- Built in PI control, EMC filter (C1) & brake chopper
- Application macros for industrial fan operation
- Bluetooth® connectivity
- Controls multiple motor types: IE2, 3, 4, IM, PM, BLDC and SynRM
- Operates up to 50°C



Overview

Compact, robust and reliable general purpose drive for panel mounting.

Simply Power Up

Eltadrive E3 provides precise motor control and energy savings using the factory settings. Simply power up and the drive can immediately deliver energy savings. 14 basic parameters allow simple adjustment for your application if required, with up to 50 parameters available in total for a highly flexible performance.

Power Supply

Connects at top.

Fast Connection

5mm rising clamp terminals with captive screws.

Quick Reference

Integrated help card.

Modbus RTS & CANopen

On board as standard.

SmartStart

Rapid parameter cloning and Bluetooth® PC interface.

Motor Supply

Connects at base.

Dimensional Data

Model	Size	Height	Width	Depth	Weight kg	Fixings
IP20	1	173	83	123	1.0	4 x M5
	2	221	110	150	1.7	4 x M5
	3	261	131	175	3.2	4 x M5
	4	420	171	212	9.1	4 x M8

Dimensions in mm.

ELTADRIVE VARIABLE SPEED DRIVES

IP66

- Up to 7.5kW
- Conformal coating as standard
- Switched or Non-Switched

Overview

Enclosed drives for direct machine mounting, dust-tight and ready for washdown duty.

Dust Tight Design

Install directly on your processing equipment and be sure of protection from dust and contaminants.

Washdown Ready

With a sealed ABS enclosure and corrosion resistant heatsink, the Eltadrive E3 IP66 is ideal for high-pressure washdown applications.

Eltadrive E3 IP66 Switched

Simply wire up the drive, turn the inbuilt potentiometer and the motor will start running - allowing immediate energy savings.

Coated Heatsink as Standard

Ideal for hygiene based operations requiring washdown such as food & beverage.

Fanless Heatsink

For reliable, cost effective operation.

Local Speed Potentiometer

Run Reverse / Off / Run Forward Switch

Lockable Mains

Disconnect / Isolator.



Dimensional Data

Model	Size	Height	Width	Depth	Weight kg	Fixings
IP66	1	232	161	179	3.1	4 x M4
	2	257	188	187	4.1	4 x M4
	3	310	211	252	7.6	4 x M4

Dimensions in mm.

FLANGED SILENCER

Accessories



- Ideal for bolting directly to fan flange
- Ideal for all axial fans
- Ideal for cross talk elimination
- Ideal for flexible or spiral ducting

Overview

Elta Fans are able to provide 2 types of cylindrical silencers as standard; Type DENP (without pod) and DEP (with pod), these are categorised as follows; Compact Silencers (ENP / EP), Standard Silencers (ENP / EP / Melinex).

Construction

Both types are rigidly constructed in galvanised sheet steel, with a highly absorbent sound attenuating lining between the outer casing and the inner perforated steel lining. The end faces of the silencer has a series of threaded holes for direct mounting to the fixing flange/flexible collar. The EP (podded versions) will provide an improved level of attenuation. The inner acoustic pod is constructed from perforated steel sheet with a sound absorbent infill.

Melinex lined silencers must be used to prevent grease impregnation into the acoustic media for kitchen extract applications as prescribed in DW/172 HVAC Specification For Kitchen Ventilation Systems. For Melinex insertion losses, please contact Elta Fans. Silencers can be provided with differing lengths: 1D = 1 times diameter, 2D = 2 times diameter. The Velocity through podded silencer should not exceed 15m/s.

Silencer Attenuation

To determine the sound level of a fan fitted with a silencer, the dynamic insertion loss should be subtracted from the sound power level spectrum (dBW) of the fan. This should be done for the entire octave band mid-frequency spectrum. The fan dBW ratings and silencer attenuation apply equally to in duct applications, with a silencer connected between the fan and the duct system.

Dynamic Insertion Loss

The silencer attenuation is defined as the “dynamic insertion loss”. The values quoted in the tables represent the difference between the sound power level of a fan and silencer combination (dBW) and that of the fan alone (dBW). The dynamic insertion losses shown are the attenuations recorded under ideal working conditions. The achieved attenuation will vary according to the air velocity and flow pattern in the airways. Noise regeneration can occur at higher velocities, especially in EP silencers.

Square / Rectangular Silencers

In highly noise sensitive areas, where the circular silencers cannot achieve the necessary attenuation levels, Elta can design and build optional splitter silencers for greater effect.

FLANGED SILENCER

Dynamic Insertion Loss & Pressure Graphs

Dynamic Insertion Loss

Fan Size	Silencer Length	Silencer Type	Insertion Loss @ Octave Band (Hz)							
			63	125	250	500	1k	2k	4k	8k
0315-0560	1D	ENP	-2	-5	-6	-9	-13	-11	-6	-6
		EP	-4	-6	-8	-11	-18	-19	-17	-14
	2D	ENP	-4	-8	-12	-17	-23	-17	-12	-10
		EP	-7	-10	-12	-21	-26	-26	-24	-22
0630-0710	1D	ENP	-3	-4	-9	-15	-15	-8	-7	-6
		EP	-4	-6	-8	-17	-23	-20	-18	-10
	2D	ENP	-6	-8	-13	-22	-22	-13	-12	-9
		EP	-8	-11	-16	-27	-32	-31	-29	-19

Podded Silencers Pressure Graphs

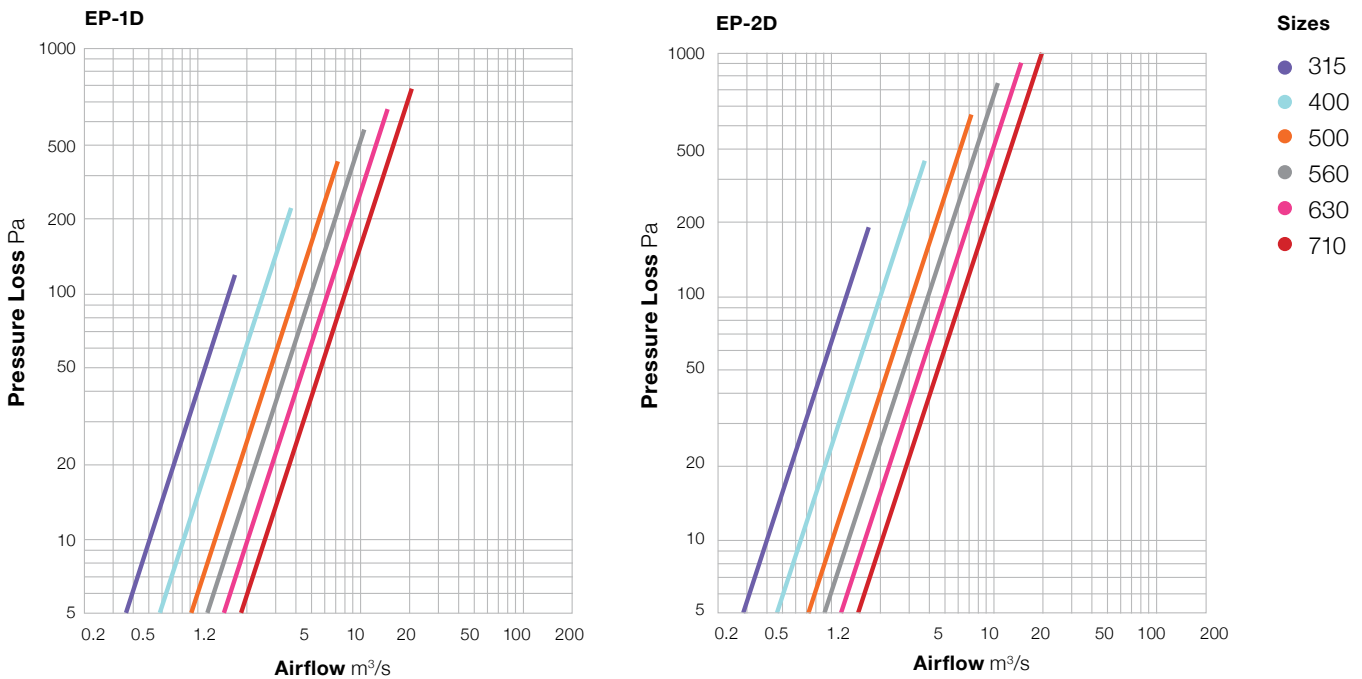

For Ø250 podded pressure losses, please contact Elta Fans.

FLANGED SILENCER

Dimensional Data

Silencer 1DENP Unpodded

Product Code	Fan Dia	A	B	C	D	E	Weight kg
068-0315-1DENP	315	315	416	8	M8	355	9
068-0400-1DENP	400	400	503	8	M10	450	13
068-0500-1DENP	500	500	657	12	M10	560	18
068-0560-1DENP	560	560	714	12	M10	620	22
068-0630-1DENP	630	630	784	12	M10	690	26
068-0710-1DENP	710	710	864	16	M10	770	32

Silencer 2DENP Unpodded

Product Code	Fan Dia	A	B	C	D	E	Weight kg
068-0315-2DENP	315	630	416	8	M8	355	15
068-0400-2DENP	400	800	503	8	M10	450	22
068-0500-2DENP	500	1000	657	12	M10	560	32
068-0560-2DENP	560	1120	714	12	M10	620	39
068-0630-2DENP	630	1260	784	12	M10	690	48
068-0710-2DENP	710	1420	864	16	M10	770	59

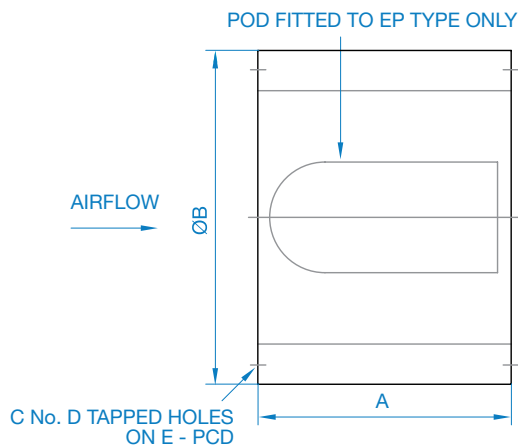

Dimensions are in mm.

HIGH TEMPERATURE FLEXIBLE CONNECTOR

Accessories

- Fit to matching flanges to provide flexible connection
- Polyurethane coated glass fiber fabric
- Supplied with plated steel band fixings
- Alternative materials available to order
- Suitable for -50°C and +200°C and up to 400°C / 2 hours



Product Code	Fan Dia. A	B	Weight kg
063-0315-PU250	315	150	0.6
063-0400-PU250	400	150	0.9
063-0500-PU250	500	150	1.2
063-0560-PU250	560	150	1.3
063-0630-PU250	630	200	1.4
063-0710-PU250	710	200	2.0

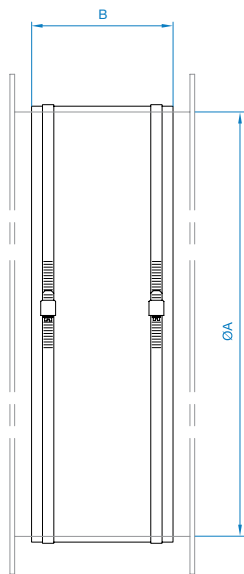

Dimensions are in mm.

MATCHING FLANGES

Accessories

- Fits directly to fan case flange
- Provides easy connection to flexible connector or ducting
- Hot dip galvanised steel



Product Code	Fan Dia. A	B	C	D	E	F	G	Weight kg
061B-0315	315	375	30	1.5	8	10	355	0.7
061B-0400	400	475	40	1.5	8	12	450	1.2
061B-0500	500	585	45	2.0	12	12	560	2.6
061B-0560	560	645	45	2.0	12	12	620	3.0
061B-0630	630	715	45	2.0	12	12	690	3.5
061B-0710	710	795	45	2.0	16	12	770	3.7

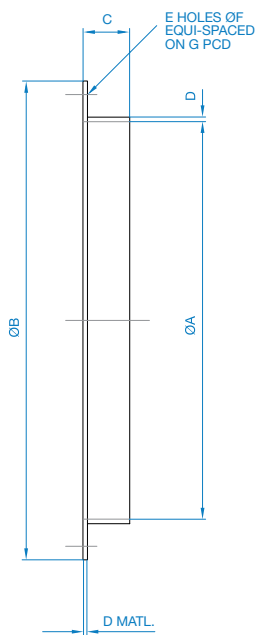

Dimensions are in mm.

TPI TRANSITION PIECE

Accessories



- For use with SQU-HT(S) range
- Rectangular to round transition
- 1.2mm galvanised steel

Product Code	A	B	C	nD (Nominal)	Weight kg
260-SQU-TPI-A	437	200	315	315	5
260-SQU-TPI-B	607	317	500	500	10
260-SQU-TPI-C	607	317	400	400	7
260-SQU-TPI-D	737	417	560	560	13
260-SQU-TPI-E	737	417	500	500	11
260-SQU-TPI-F	937	567	630	630	18
260-SQU-TPI-G	937	567	710	710	20

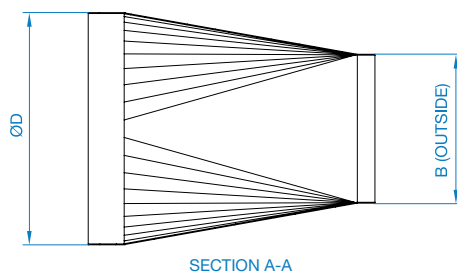
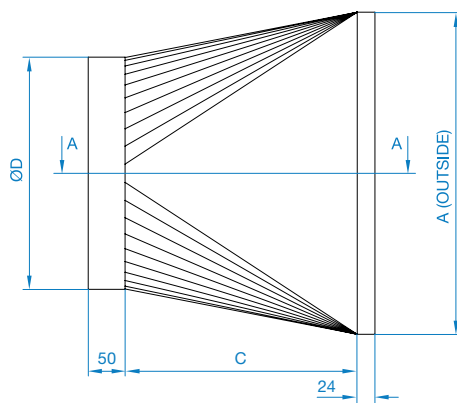

Dimensions in mm.

TPO TRANSITION PIECE

Accessories



- For use with SQU-HT(S) and SSQU range
- Rectangular to round transition
- 1.2mm galvanised steel

Product Code	A	B	C	ØD	Weight kg
260-SQU-TPO-A	437	215	315	315	5
260-SQU-TPO-B	607	269	500	500	9
260-SQU-TPO-C	607	269	400	400	7
260-SQU-TPO-D	737	299	560	560	12
260-SQU-TPO-E	737	299	500	500	10
260-SQU-TPO-F	937	349	630	630	18
260-SQU-TPO-G	937	349	710	710	18
260-SSQU-TPO-A	437	162	315	315	4
260-SSQU-TPO-B	607	222	500	500	9
260-SSQU-TPO-C	607	246	400	400	8
260-SSQU-TPO-D	737	239	560	560	12
260-SSQU-TPO-E	737	301	500	500	11
260-SSQU-TPO-F	937	295	710	710	18
260-SSQU-TPO-G	937	343	710	710	18
260-SSQU-TPO-H	937	343	630	630	16

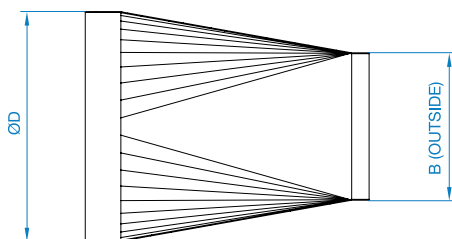
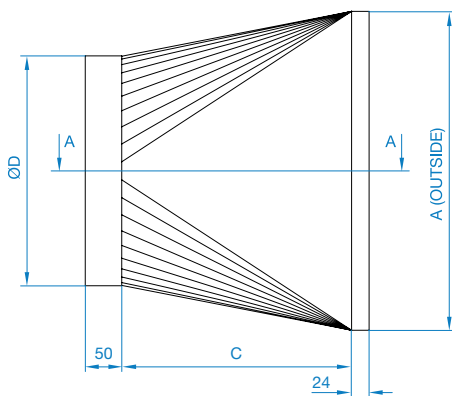

SECTION A-A

Dimensions in mm.

VERTICAL WEATHER HOOD

Accessories



- For use with SQU-HT(S) and SSQU range
- External Weather Hood for outdoor applications
- Pre-fitted birdguard
- 0.9mm galvanised steel

Product Code	A	B	C	D	Weight kg
064-SQU-WHV-A	437	202	562	126	4
064-SQU-WHV-B	607	272	731	126	6
064-SQU-WHV-C	737	303	862	126	8
064-SQU-WHV-D	937	352	1062	126	12

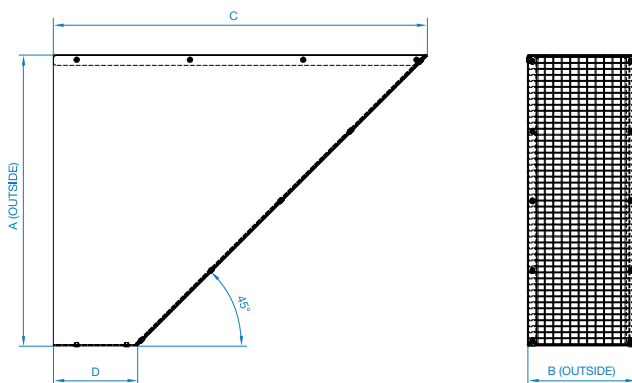

Dimensions are in mm.

Building Services

Tel **+44 (0) 1384 275800**
Fax **+44 (0) 1384 275810**
Email **info@eltafans.co.uk**

46 Third Avenue, Pensnett Trading Estate, Kingswinford,
West Midlands, DY6 7US United Kingdom

Applied Technology & Building Services Export

Tel **+44 (0) 1489 566500**
Fax **+44 (0) 1489 566555**
Email **at@eltafans.co.uk / export@eltafans.co.uk**

17 Barnes Wallis Road, Segensworth East Industrial Estate,
Fareham, Hampshire, PO15 5ST United Kingdom

eltafans.com

SQUHT-11-2018 Issue B



BS EN ISO 9001:2015 FM 556465

